

100%
made in
ITALY



PS30CL

MODEL	FLOOR VERS.	INGROUND VERS.	MAX HEIGHT(cm)	GATE	RAMP, TOOLS HOLDER KIT	COLOR KIT	ISOL8 VERS.
C	✓	-	110	✓	✓	✓	✓
HC	✓	-	130	✓	✓	✓	✓
HCF	-	✓	130	✓	-	-	✓

Caratteristiche tecniche

- Sicurezze elettriche
- Sicurezze meccaniche
- Sicurezze idrauliche
- Portata: 600kg
- Centralina elettroidraulica integrata

Dotazioni di serie

- 2 vaschette porta utensili laterali
- Rampa di salita
- Fermaruota

Technical Features

- Electrical Safety device
- Mechanical safety device
- Hydraulic safety devices
- Capacity: 600kg
- Integrated electro-hydraulic unit

Standard Equipments

- 2 side tools holders
- Run-up ramp
- Front safety bar



Gate a scomparsa
Retractable gate



Un cilindro di sollevamento
One lifting cylinder

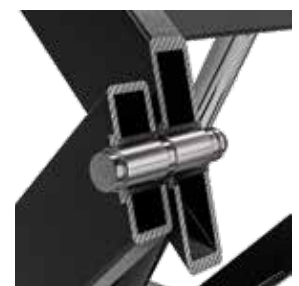

Boccole autolubrificanti
Skid sliding system with self-lubricating plastic material

Model "C"

**Model "HC"
Model "HCF"**

with max. height + 200 mm

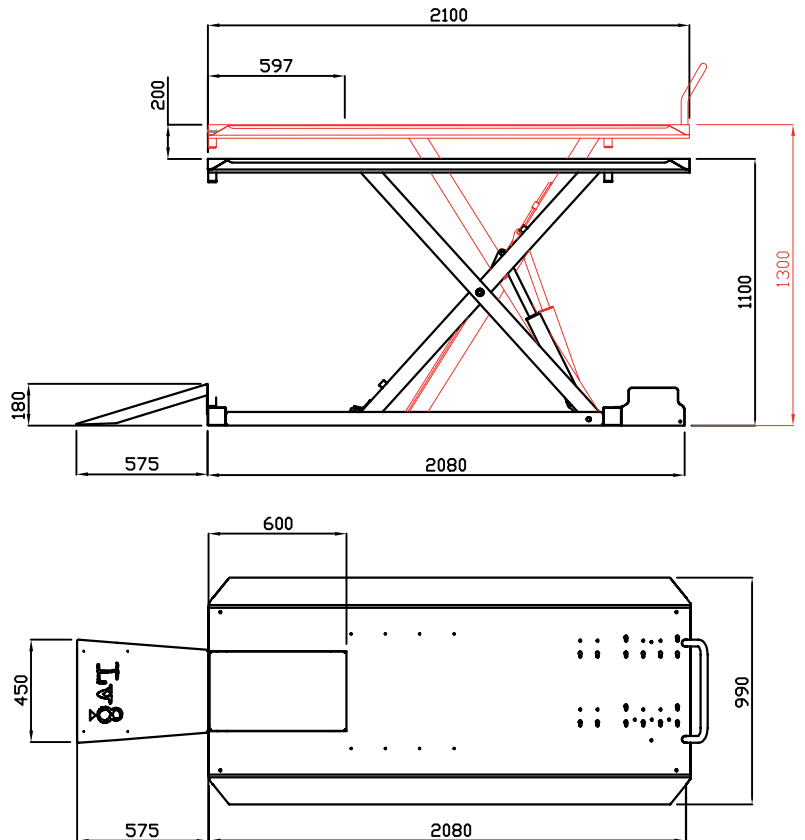
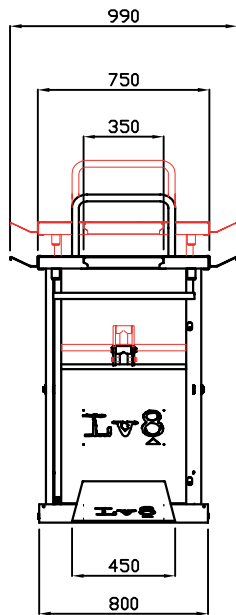

OPTION



EGHC600

Cornice ad incasso
cm 214x9xH18
In ground frame
cm 214x79xH18



EG600.7L

Rampa larga (75x80 cm)
Large ramp (75x80 cm)



EG600FEK

Front Extension per pianale
cm.75x35
Front Extension cm.75x35



EIE-LTPNK01

Kit radiocomando
Remote control kit

CUSTOMIZE YOUR COLOR!



Personalizza il tuo sollevatore con i nostri kit colore
Customize your lift with our colour kits

GO TO PAGE ► 23

SAFETY FIRST!



Rendi il tuo sollevatore idoneo alla manutenzione delle moto elettriche
Make your lift suitable for maintenance work on electric motorcycles

GO TO PAGE ► 24

ADD THE ACCESSORIES!

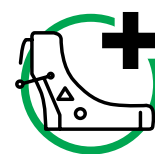

Seleziona gli accessori da aggiungere al sollevatore
Select the accessories you want to add to the lift

GO TO PAGE ► 30